

**D.**

DICERAMICA

---

TABLES ASSEMBLY INSTRUCTIONS

# ASSEMBLY INSTRUCTION

0\_ Packaging Content / Contenuto imballaggio :

**LEGS ( n.2 items ) / GAMBE ( n.2 pezzi )**

V shape

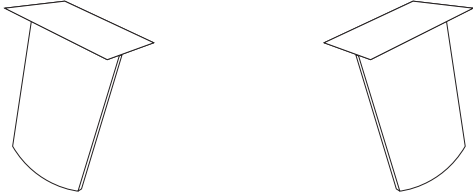

**SCREWS FOR LEGS  
(n.8 items) /  
VITI PER GAMBE  
(n.8 pezzi)**



**SCREWS FOR  
FRAME-TOP FIXING  
(n.6 items) /  
VITI PER FISSAGGIO  
TELAIO-TOP  
(n.6 pezzi)**



**SPACERS  
(n.6 items) /  
DISTANZIALI  
(n.6 pezzi)**



**FRAME / TELAIIO**

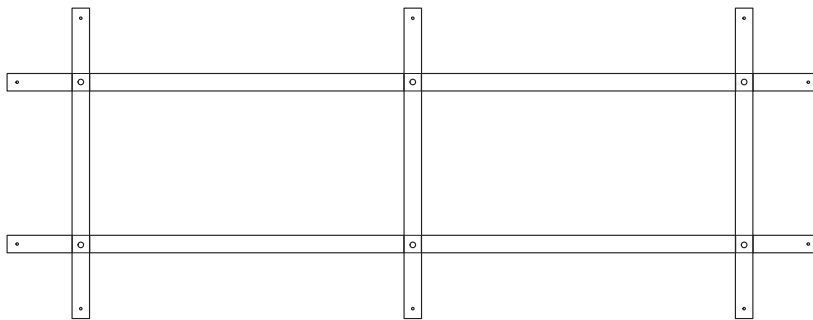

**TOP ( bushings on back ) / PIANO ( boccole fissate sul retro )**

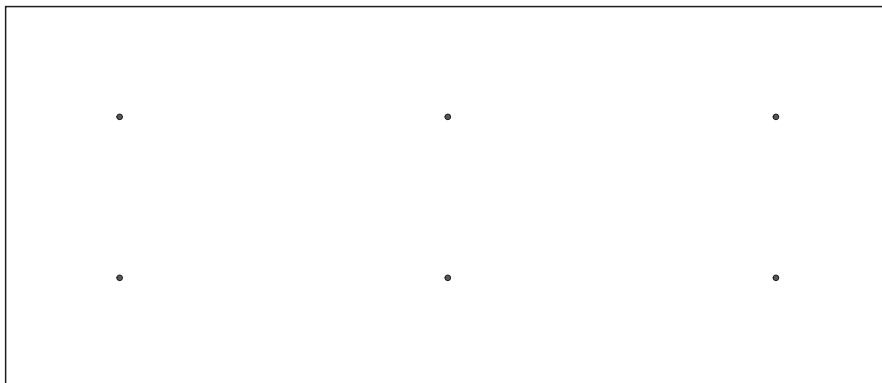

BACK side

# **ASSEMBLY INSTRUCTION**

## **1\_ FRAME PLACEMENT / POSIZIONAMENTO TELAIO**

Upside down the FRAME on the floor. Insert a spacer for each existing bushing on the top.

Capovolgere il TELAIO e posizzarlo a terra. Inserire un distanziale per ogni boccola già presente sul top.

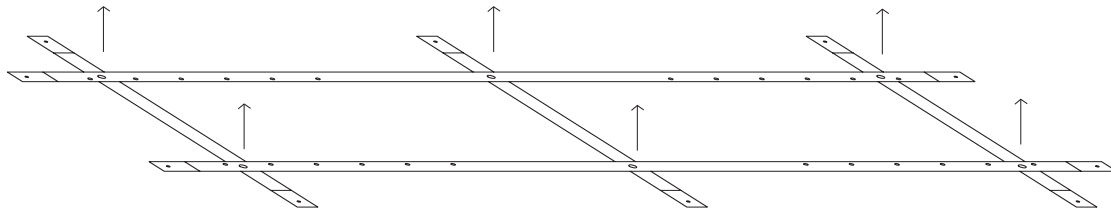

## **2\_ LEG FIXING / FISSAGGIO GAMBE**

Match the fixing holes between the LEGS and the FRAME and screw.

Far combaciare le forometrie di fissaggio tra GAMBE e TELAIO ed avvitare.

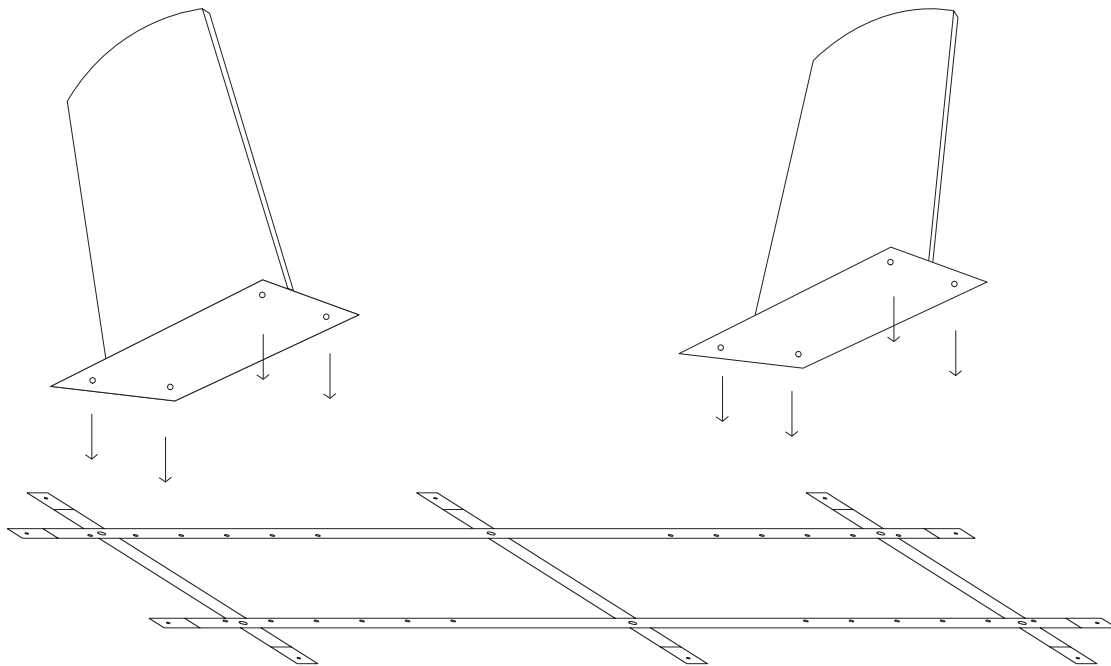

## **ASSEMBLY INSTRUCTION**

### **3\_ STRUCTURE OVERTURNING / RIBALTAMENTO STRUTTURA**

Turn the FRAME+LEGS structure over again so that LEGS rest on the ground.

Ribaltare nuovamente la struttura formata da TELAIO+GAMBE in modo che le GAMBE del tavolo appoggino a terra.

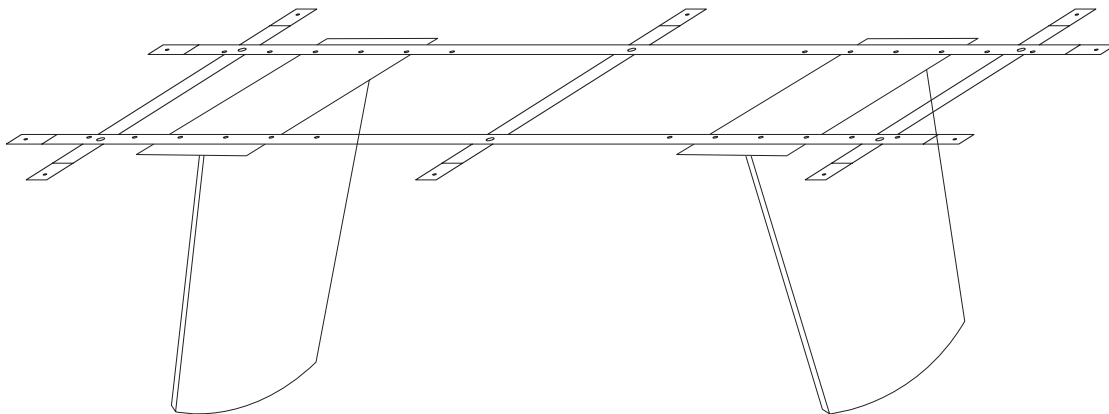

### **4\_ TOP - FRAME FIXING / FISSAGGIO TOP AL TELAIO**

Insert spacers into top bushings. Place the TOP on the FRAME by matching the holes of the cross members on the frame with the spacers at the back of the table. Fix the TOP to the FRAME from below, using the appropriate screws.

Inserire i distanziali nelle boccole del top. Appoggiare il TOP sul TELAIO facendo combaciare i fori dei traversi sul telaio con i distanzianti della parte posteriore del tavolo. Fissare da sotto, tramite le apposite viti, il TOP al TELAIO.

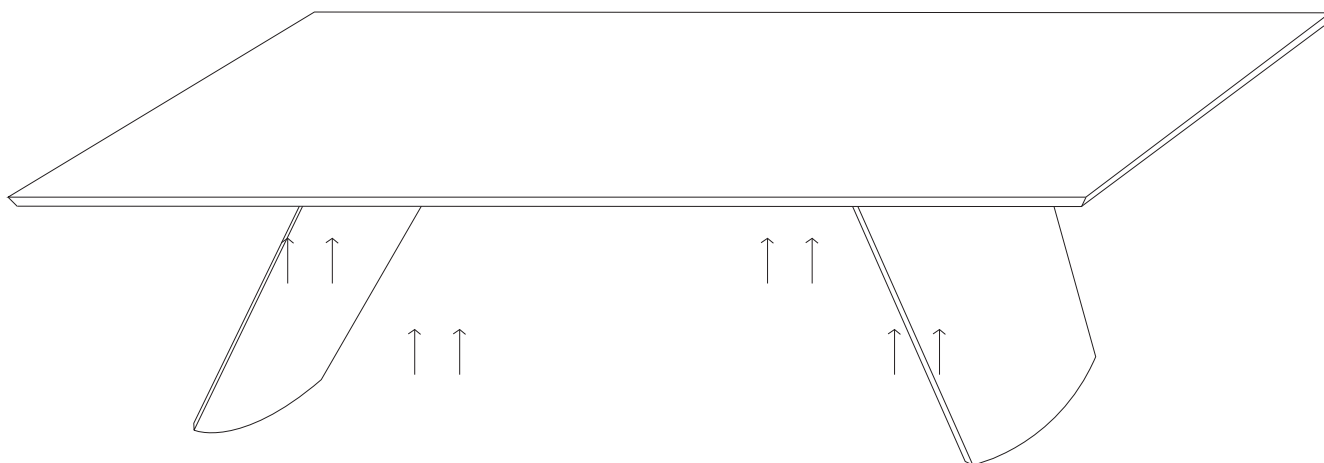

\*DO NOT GET ON THE TABLE. DO NOT DRAG. DO NOT RAISE FROM THE BASEMENT.

\*NON SALIRE SUL TAVOLO. NON TRASCINARE. NON SOLLEVARE DAL PIEDE.